



**Model JEEPKIT-1 / JEEPKIT-99
Bolt-on Air Horn & Compressor Kit for Jeep Wrangler JK**

IMPORTANT:

It is essential that you and any other operator of this product read and understand the contents of this manual before installing and using this product.

SAVE THIS MANUAL FOR FUTURE REFERENCE

USER MANUAL

□ Model JEEPKIT-1 / JEEPKIT-99

Components:

- 1 0.66-Gallon - 4-port air tank
- 1 Model 6260RC compressor
- 1 Dual trumpet air horn (Either model 101 or 99)
- 1 Installation wiring & connector kit
- 1 Compressor installation hardware (Package #1 - inside compressor box)
- 1 JEEPKIT mounting hardware (Package #2)
- 1 Compressor/Tank mounting bracket
- 1 Horn mounting bracket
- 1 12' length air tubing

PARTS PACKAGES

Package #1 – Compressor Installation Hardware

- Qty 4 13/64" Nuts, bolts, washers & locking washers
(Compressor mounting hardware)



- Qty 1 Remote Mount Air Filter Assembly



- Qty 1 Remote mount air filter fitting for air filter connection



- Qty 1 Replacement air filters



- Qty 1 Leader Hose Bracket Clip



- Qty 1 Air line for remote mounting air filter



Package #2 – Jeep Kit bracket and tank hardware

Qty 6 5” bolts
Qty 6 Nyloc nuts
Qty 3 Rear mount plates
Qty 4 Nuts, bolts, and washers – (Air tank mounting hardware)



Compressor/Tank – General Information

Your Jeep Kit comes complete with a model 6260RC, 10% duty cycle air compressor and a 0.66-gallon air tank. Please follow the installation instructions that follow in order to enjoy the best use of your air horn kit.

CAUTION - To reduce risk of electrical shock or electrocution:

- Do not disassemble the compressor. Do not attempt repairs or modifications. Refer to qualified service agencies for all service and repairs.
- Do not use this product in an area where it can fall or be pulled into water or liquids.
- Do not reach for this product if it has fallen into liquid.
- Use this compressor with 12-volt DC systems only.
- This product should never be left unattended during use.

IMPORTANT:

- Tank is rated for 120 PSI maximum working pressure.
- Tank is not to be used as a breathing device.
- Bleed pressure from tank before servicing or adding attachments.
- Use only attachments or tools rated for 120 PSI working pressure or less.
- Apply sealant or Teflon tape to threads of fittings prior to assembly and tighten each part with a wrench.
- Do not over tighten, since brass threads can be stripped.
- Always release air from tank before servicing.
- To remove accumulated condensation inside the tank, disconnect power from the compressor and release the pressurized air by sounding the horns. Unbolt the air tank, then drain water by removing the drain plug at the bottom of the tank. Once the water is drained, replace the plug and re-mount the tank. Use Teflon thread tape to ensure a good seal.

CAUTION:

DO NOT PRESSURIZE YOUR TANK UNTIL YOU HAVE INSTALLED ALL NECESSARY PORT FITTINGS AND ACCESSORIES. FAILURE TO DRAIN TANK AND REMOVE CONDENSATION WILL CAUSE TANK TO RUST PREMATURELY. RUSTED TANKS CAN FAIL CAUSING EXPLOSIONS OR FATAL INJURIES. DISCARD TANK IMMEDIATELY IF IT IS RUSTED.

Compressor/Tank Installation

Included in your kit is a vehicle-specific mounting bracket for the compressor and air tank. The bracket clamps around the horizontal beam located above the rear differential.

Preparation

1. Locate the horizontal beam above the rear differential. There is a small wiring harness, attached to the top of the support with two plastic clips. Remove the clips to allow free movement of the wiring harness. It is not necessary to salvage the clips – they will not be re-used (see photo 1).
2. Attach the compressor to the vehicle-specific mounting bracket using the bolts in Package 2. The compressor should be mounted with the piston on the driver's side of the vehicle, facing away from the tank mounting location. Bring the bolts up through the bottom of the mounting plate and have the nuts on the top. **Do not mount the tank yet.**
3. Insert two 5" mounting bolts into each rear mount plate (see photo 2).



Photo 1 – Horizontal beam with wiring harness clips removed



Photo 2 – Rear Mount Plates with bolts inserted

Mounting the compressor/tank bracket

1. Work from the driver's side of the vehicle and slide all three rear mount plate/mounting bolt sub-assemblies onto the horizontal beam. The rear mount plates should be towards the rear of the vehicle, the bolts should be extending over and below the beam, pointing toward the front of the vehicle (see photo 3). As each sub-assembly is positioned over the beam, slide it towards the passenger side of the vehicle so that the three sub-assemblies are spaced at roughly the same intervals as the three sets of mounting holes on the bracket (see photo 4). Make sure the wiring harness you detached from the beam earlier is lying on TOP of the bolts and not running under the bolts! *Helpful Tip: Using electrical tape to temporarily hold the bolts on the rear mount plates will make this task easier.*



Photo 3 – Slide the rear mount plate/bolt assemblies over the beam. Work from the driver's side and slide the assemblies towards the passenger's side

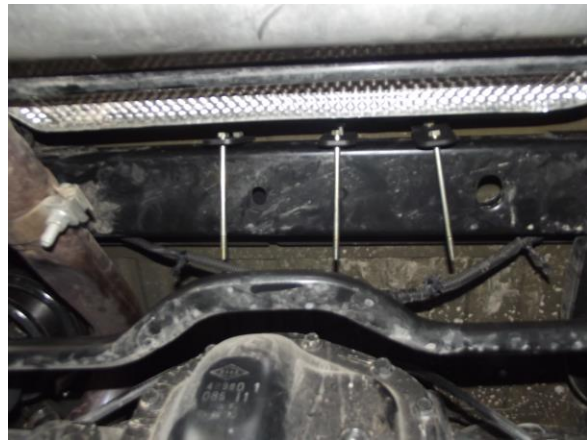

Photo 4 – All three rear mount plate/bolt assemblies in place.

2. Position the bracket in front of the beam, then align the rear mount/bolt assemblies so that the bolts pass through the mounting holes in the bracket. Hand tighten the six Nyloc nuts onto the bolts.
3. Position the entire bracket assembly towards the passenger side of the beam. There is a welded joint at the end of the beam – the bracket should be butted up against that weld. **Do not try to attach the bracket over the weld** (see photos 5 & 6)
4. Using an 11mm gear wrench or a ratchet with a 6" extension, tighten the six Nyloc nuts. Alternate between top and bottom so that the rear mount plates sit flush against the back of the beam and the bolts sit flush on the top and bottom of the beam. Use a wrench to hold the bolt heads while tightening.
5. Attach a short section (approx 12-18") of the black tubing in the compressor accessory package to the air intake on the front of the compressor. Route the other end into the existing opening in the floor brace just above the compressor.



Photo 5 – Compressor on mounting bracket, as seen from the front of the vehicle.



Photo 6 – Mounting bracket, as seen from underneath.

Making the air connections

1. Temporarily slip the emergency brake cables out of their support to allow room for installing the air tank. Position the air tank on top of the mounting bracket with the fittings facing the driver's side of the vehicle and the compressor. Do not attach the tank to the bracket yet (see photo 7).
2. Remove the red rubber plug from the end of the steel braided leader hose on the compressor and apply Teflon thread tape to the threads on the check valve at the end of the leader hose.
3. Make a loop with the leader hose and position the hose between the compressor body and the back of the bracket (see photo 8).
4. Thread the leader hose into the tank and tighten with a wrench. It is important that the connection is snug, but not over tightened. When the brass female adapter on the tank starts turning, you've tightened the leader hose enough.
5. Connect the air tube to the compression fitting on the tank. For best results, make sure the end of the tube is cut clean and square. Route the tube over the top of the bracket that holds the Jeep EVAP canister.



Photo 7 – Emergency brake cable support



Photo 8 – Air tank positioned on mounting bracket. Note how the braided steel leader hose is looped between the compressor body and the mounting bracket.

Mounting the air horn

1. Locate the EVAP canister under the vehicle. It is towards the driver's side, just forward of the rear axle (see photo 9).
2. Remove the two 5/8" bolts for the EVAP canister mounting bracket.
3. Use the mounting bolts found inside the horn box to attach the horns to the horn mounting bracket
4. Cut your tubing to length, making sure the end is clean and square. Connect the air line to the solenoid valve, then slip the horn mounting bracket **UNDER** the EVAP canister bracket and align the holes. Re-install the 5/8" bolts through the EVAP canister mount and the horn bracket (see photo 10)



Photo 9 – EVAP canister. Note the two 5/8” mounting bolts

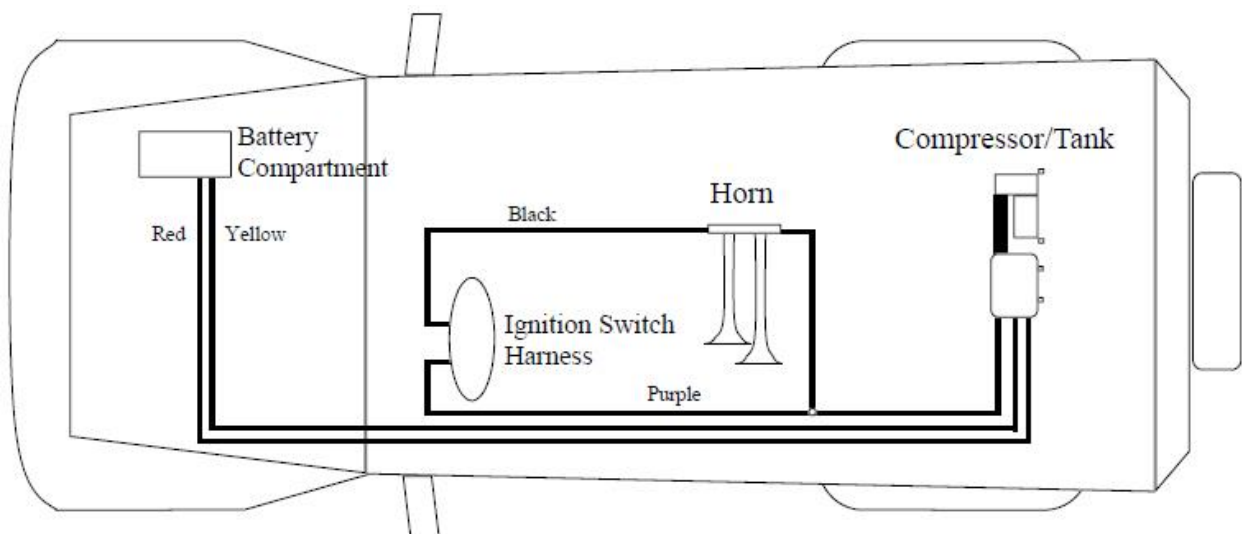

Photo 10 – Air horn bracket mounted under EVAP unit bracket

Pre-wiring

1. Disconnect ground cable from vehicle's battery.
2. Ground the compressor black wire. The nut that secures the emergency brake cable support just forward and above the rear differential is a good grounding point.
3. Your wiring kit includes red, yellow, purple and black wires that will need to be run the length of the vehicle. Run the red and yellow wires from the battery area (passenger side), across the engine compartment, and back to the compressor/tank.
4. Run the black and purple wires to the back from the area of the ignition switch harness (under the steering column). The black wire will terminate at the air horns, the purple wire will run all the way back to the compressor/tank.

Be sure to keep your wiring away from heat sources such as the exhaust!



Wiring Connections

1. Use the relay including in your wiring package to supply power to the compressor. Mount the relay near the battery and wire as follows:

- Pin 30 – to the 10 gauge red wire that runs the length of the vehicle and attaches to the red wire on the compressor
- Pin 85 – to the yellow wire runs the length of the vehicle to one side of the pressure switch (it does not matter which terminal)*
- Pin 86 – to ground
- Pin 87 – to one end of the fuse holder (cut the loop)

** before attaching spade connectors to the ends of the wires that connect to the pressure switch, pass the wires through the opening in the black rubber pressure switch cover. Slide the cover over the pressure switch once the connections have been completed.*

2. Connect the end of the purple wire at the compressor/tank to the open terminal on the pressure switch. Connect the other end of the purple wire to the 12v+ ignition wire in the ignition switch harness.
3. The black wire will be your horn trigger. If you want to activate your horn using the pushbutton supplied with the kit, connect one side of the pushbutton to ground and the other side of the pushbutton to the black wire. If you want to use your factory horn switch instead of the pushbutton, connect the black wire to the vehicle (-) horn wire, located in the ignition switch harness. In either scenario, the other end of the black wire should be connected to one of the wires (it doesn't matter which) coming out of the solenoid valve on the air horn.
4. Use a leftover section of your black wire to connect the remaining wire on the air horn solenoid valve to +12v ignition. You can use the +12v ignition you already have running to the back of the vehicle via the purple wire.
5. Connect the remaining end of the fuse holder to the + terminal of the battery or the 'power point' on the corner of the fuse box, in front of the battery.
6. Insert the fuse in the fuse holder to complete your wiring
7. Use the wire loom supplied with the kit to protect your wiring!
8. Use the supplied wire ties to secure the factory wiring harness that was detached earlier to the holes on the compressor mounting bracket.

Mounting the air tank

1. After all electrical connections have been completed, pressure test the tank before bolting it to the bracket. To pressure test the tank, complete your wiring and turn on the ignition to run the compressor. Once the pressure switch shuts the compressor off, spray soapy water on all the air connections at the tank. If you see bubbles, tighten the connection slightly or add more Teflon tape.
2. Once you have pressure tested the system, the tank can be mounted to the bracket. Use the four nuts, bolts and washers included in hardware package #1. Install the bolts from the top downward. *Helpful Tip: The passenger side rear bolt will be difficult to access. Use a piece of electrical tape to temporarily hold the bolt into the tank's foot when doing your final positioning of the tank on the bracket.*

COMPRESSOR OPERATING INSTRUCTIONS

IMPORTANT: The compressor has a maximum working pressure of 120 PSI and is capable of 10% duty cycle. It is designed for use with air horns, air bags and other accessories that utilize the compressed air stored in the tank. Always operate the compressor at or below the **MAXIMUM PRESSURE RATING** of the compressor. Operation exceeding maximum pressure ratings and or duty cycle will result in damage to air compressor.

1. Your air compressor is equipped with an **AUTOMATIC THERMAL OVERLOAD PROTECTOR**. This feature is designed to protect the air compressor from overheating and causing permanent damage to your air compressor. The thermal overload protector will automatically cut off power to your air compressor should the internal operating temperature of the air compressor rise above safe levels during excessive use.
2. Should your air compressor automatically shut off while in use; do not attempt to restart the air compressor. Turn power switch to the air compressor to the **OFF** position. The automatic thermal overload protector will automatically reset when internal temperature of the air compressor drops below safe level. After allowing air compressor to cool off for about 30 minutes, you can safely resume use of the air compressor by turning on the air compressor.
3. To prevent discharge of your vehicle's battery and to provide peak performance, we strongly recommend that you keep the vehicle's engine running while using the air compressor.
4. **ONLY OPERATE THE AIR COMPRESSOR IN WELL-VENTILATED AREAS.**

Compressor Maintenance & Repairs

1. Periodically check all electrical and fitting connections. Clean and tighten as needed.
2. Periodically check all mounting screws. Tighten as needed.
3. Replace air filter element periodically. Replacement frequency depends on operating frequency and operating environment. For frequent use in dusty environment, you should replace air filter element more often.
4. Regularly clean dust and dirt from compressor.
5. Your air compressor is equipped with permanently lubricated, maintenance free motor. Never lubricate compressor.
6. Repairs should be performed by Manufacturer or Manufacturer's Authorized Service Agencies only.

CAUTION: Never touch the air compressor or fittings connected to the air compressor with bare hands during or immediately after use. Leader hose and fittings will become very **HOT** during and after use.

□ **Kleinn Model JEEPKIT-1 / JEEPKIT-99**

LIMITED WARRANTY

Kleinn Air Horns warrants this product, when properly installed and under normal conditions of use, to be free from defects in workmanship and materials for a period of one year from provided date of purchase. To receive a replacement or for repairs, return the complete unit to retailer from whom it was purchased along with proof of purchase.

Returns should be made within the time period and conditions of the retailer's policy for exchanges. If you are unable to contact your dealer, contact Kleinn directly for repairs or replacement at our option.



**Kleinn Air Horns
4045 N Highway Dr
Tucson, AZ 85705
Phone: (520) 579-1531
Fax: (520) 579-1528
info@kleinn.com**